

THIS DRAWING ONLY APPLIES TO THE ACTION MODEL.

EX & EXS with .810 ϕ Bolt Face for 50 BMG Cartridge

NOTES:

THREAD SIZE: 1-1/2 X 16
 THREAD PROFILE: 60° V
 TPI: 16
 MAJOR DIA: 1.494
 PITCH: .062
 PITCH DIAMETER: 1.458

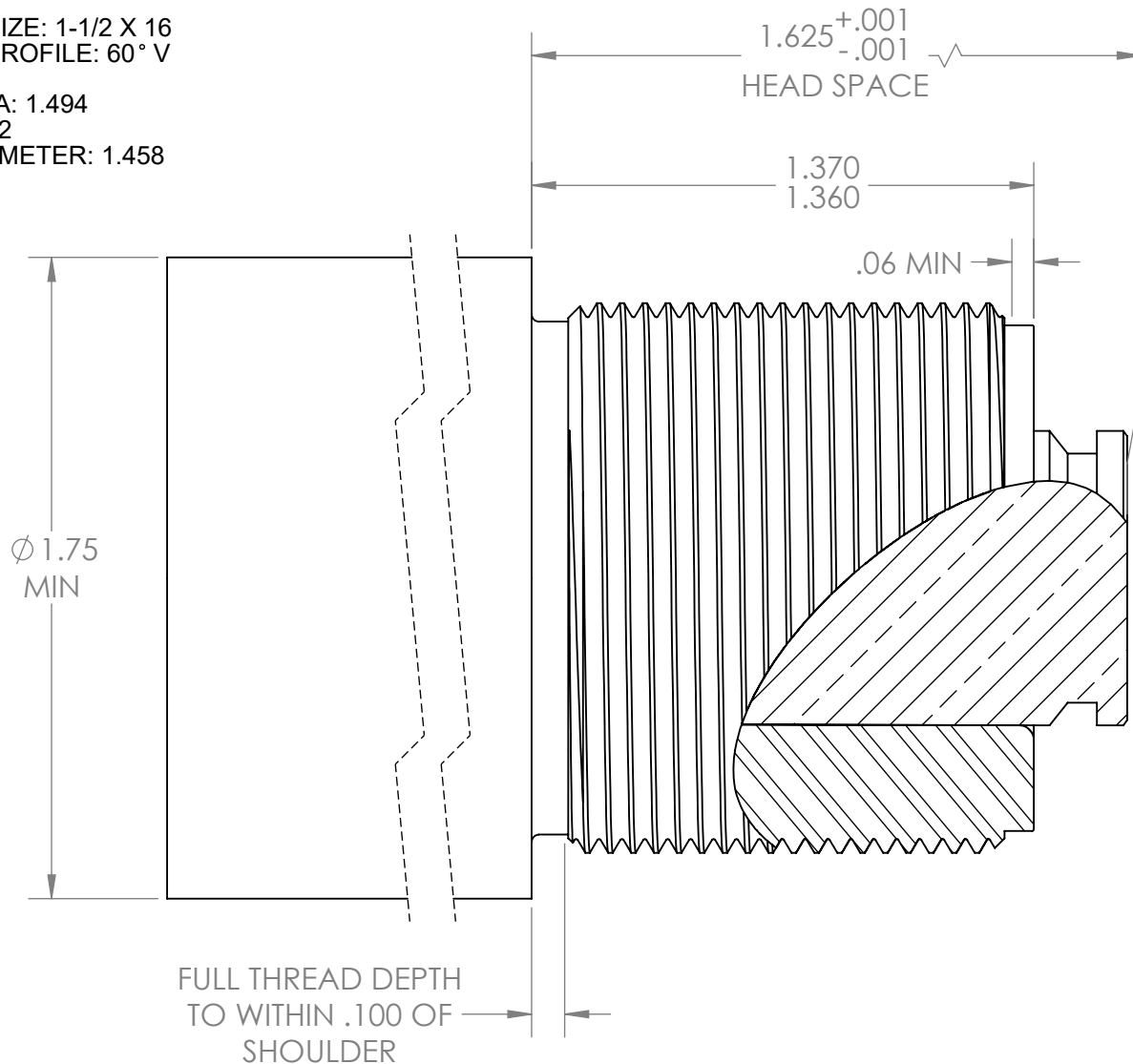

WARNING:

1. There have been some bastard actions due to customer request or rework. It is your responsibility to verify the thread size in the action you are chambering for.
2. BAT Machine Inc. builds custom actions that may or may not match this drawing, and does not accept any liability from the use or misuse of this information. ALL actions should be measured individually.
3. The end user is solely responsible for the safe use of the product.

<p>PROPRIETARY AND CONFIDENTIAL</p> <p>THE INFORMATION CONTAINED IN THIS DRAWING IS THE SOLE PROPERTY OF BAT MACHINE CO. INC. ANY REPRODUCTION IN PART OR AS A WHOLE WITHOUT THE WRITTEN PERMISSION OF BAT MACHINE CO. INC. IS PROHIBITED.</p>	<p>DIMENSIONS ARE IN INCHES TOLERANCES UNLESS OTHERWISE SPECIFIED:</p> <p>ANGULAR: ± 1 DEGREE TWO PLACE DECIMAL $\pm .005$ THREE PLACE DECIMAL $\pm .001$</p>	NAME	DATE	<p>BAT Machine Co. Inc.</p> <p>1-1/2 X 16 EX/EXS BMG</p>
		DRAWN	D. Thom	
	MATERIAL	CHECKED	B. Thom	12/23/2013
	FINISH	ENG APPR.		
	DO NOT SCALE DRAWING	MFG APPR.		
		Q.A.		
		COMMENTS:		
				SIZE A DWG. NO. tenon-1500 REV. C SCALE:2:1 WEIGHT: SHEET 1 OF 1