

THIS DRAWING APPLIES ONLY TO THE FOLLOWING ACTION MODELS.

BTLA, BTLE, Vesper M, Vesper , Igniter M & Igniter LA

NOTES:

THREAD SIZE: 1-1/8 X 16
 THREAD PROFILE: 60° V
 TPI: 16
 MAJOR DIA: 1.121
 PITCH: .0625
 PITCH DIAMETER: 1.081

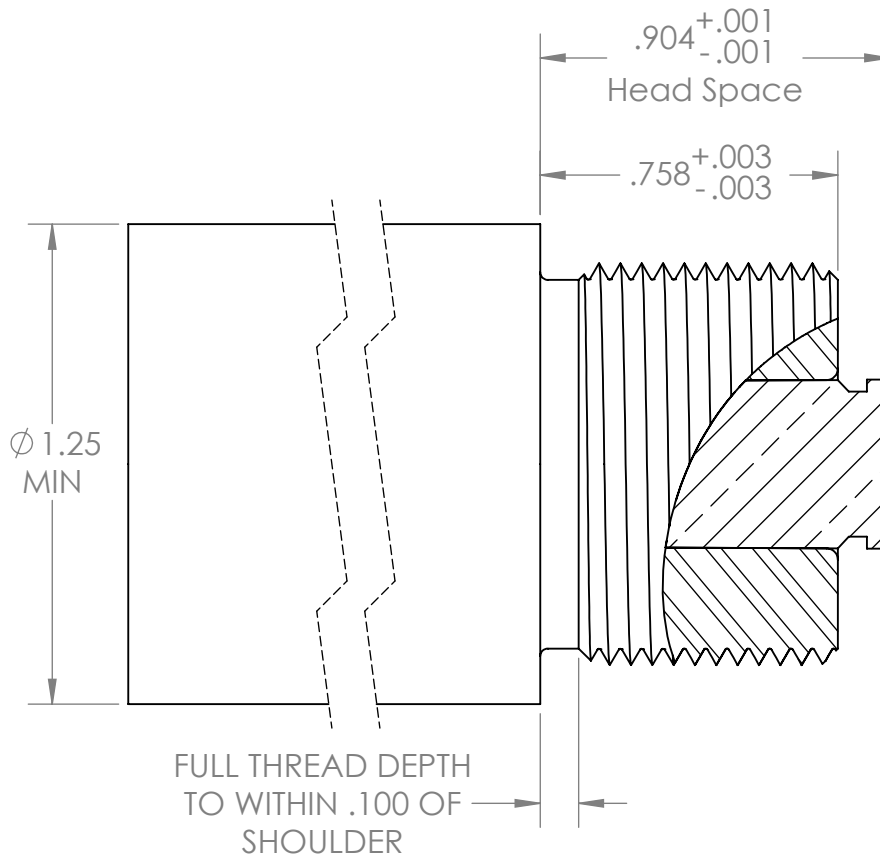

WARNING:

1. Length of thread shank will vary depending on the serial number of the action, see table above.
2. There have been some bastard actions due to customer request or rework. These utilize an oversize 1-1/8 thread. It is your responsibility to verify the thread size in the action you are chambering for.
3. BAT Machine Inc. builds custom actions that may or may not match this drawing. and does not accept any liability from the use or misuse of this information. ALL actions should be measured individually.
4. The end user is solely responsible for the safe use of the product.

<p>PROPRIETARY AND CONFIDENTIAL</p> <p>THE INFORMATION CONTAINED IN THIS DRAWING IS THE SOLE PROPERTY OF BAT MACHINE CO. INC. ANY REPRODUCTION IN PART OR AS A WHOLE WITHOUT THE WRITTEN PERMISSION OF BAT MACHINE CO. INC. IS PROHIBITED.</p>	<p>DIMENSIONS ARE IN INCHES TOLERANCES UNLESS OTHERWISE SPECIFIED:</p> <p>ANGULAR: ± 1 DEGREE TWO PLACE DECIMAL ±.005 THREE PLACE DECIMAL ±.001</p>	NAME	DATE	<p>BAT Machine Co. Inc.</p> <p>1-1/8 X 16</p> <p>LA</p>
		DRAWN	D. Thom	
CHECKED	K. Bauer	12/27/2013		
ENG APPR.				
		MFG APPR.		
		Q.A.		
		COMMENTS:		
	FINISH			SIZE DWG. NO. REV.
	DO NOT SCALE DRAWING			A tenon-1125LA D
		SCALE:2:1	WEIGHT:	SHEET 1 OF 1