

**THIS DRAWING APPLIES ONLY TO
THE ACTION MODEL.**

M, M-H & MST

NOTES:

THREAD SIZE: 1-1/8 X 16
 THREAD PROFILE: 60° V
 TPI: 16
 MAJOR DIA: 1.121
 PITCH: .0625
 PITCH DIAMETER: 1.081

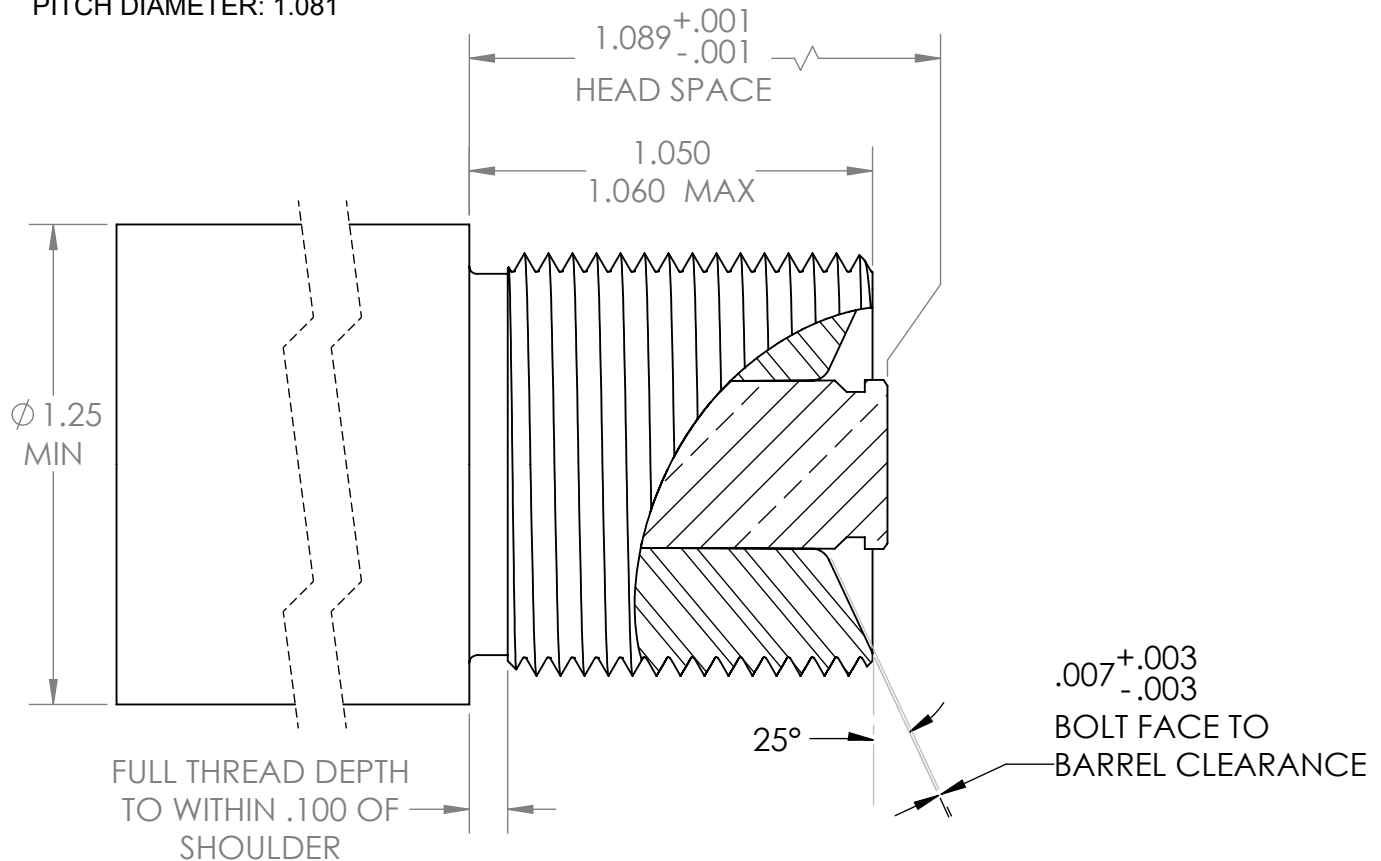

WARNING:

1. All of the model M actions with the 408 Chey-Tac bolt face have the larger 1-3/16 x 16 threads. There have been some bastard actions due to customer request or rework. It is your responsibility to verify the thread size in the action you are chambering for.
2. Length of thread extension & size of cone will vary depending on the size of the bolt face and must be individually fit.
3. BAT Machine Inc. builds custom actions that may or may not match this drawing, and does not accept any liability from the use or misuse of this information. ALL actions should be measured individually.
4. The end user is solely responsible for the safe use of the product.

<p>PROPRIETARY AND CONFIDENTIAL THE INFORMATION CONTAINED IN THIS DRAWING IS THE SOLE PROPERTY OF BAT MACHINE CO. INC. ANY REPRODUCTION IN PART OR AS A WHOLE WITHOUT THE WRITTEN PERMISSION OF BAT MACHINE CO. INC. IS PROHIBITED.</p>	<p>DIMENSIONS ARE IN INCHES TOLERANCES UNLESS OTHERWISE SPECIFIED: ANGULAR: ± 1 DEGREE TWO PLACE DECIMAL ± .005 THREE PLACE DECIMAL ± .001</p>	NAME	DATE	<p>BAT Machine Co. Inc.</p> <p>1-1/8 X 16 BR</p>
		DRAWN	D. Thom	
	<p>MATERIAL</p> <p>FINISH</p> <p>DO NOT SCALE DRAWING</p>	CHECKED	B. Thom	12/23/2013
		ENG APPR.		
		MFG APPR.		
		Q.A.		
		<p>COMMENTS: 5-19-2014 CHANGED HEAD SPACE D. THOM</p>		<p>SIZE A DWG. NO. tenon-1125 REV. C</p> <p>SCALE:2:1 WEIGHT: SHEET 1 OF 1</p>