

**THIS DRAWING APPLIES ONLY TO THE FOLLOWING ACTION MODELS.**

**S, SV, B, DS, 3L, 3LL**

**NOTES:**

THREAD SIZE: 1-1/16 X 18  
 THREAD PROFILE: 60° V  
 TPI: 18  
 MAJOR DIA: 1.060  
 PITCH: .0556  
 PITCH DIAMETER: 1.023

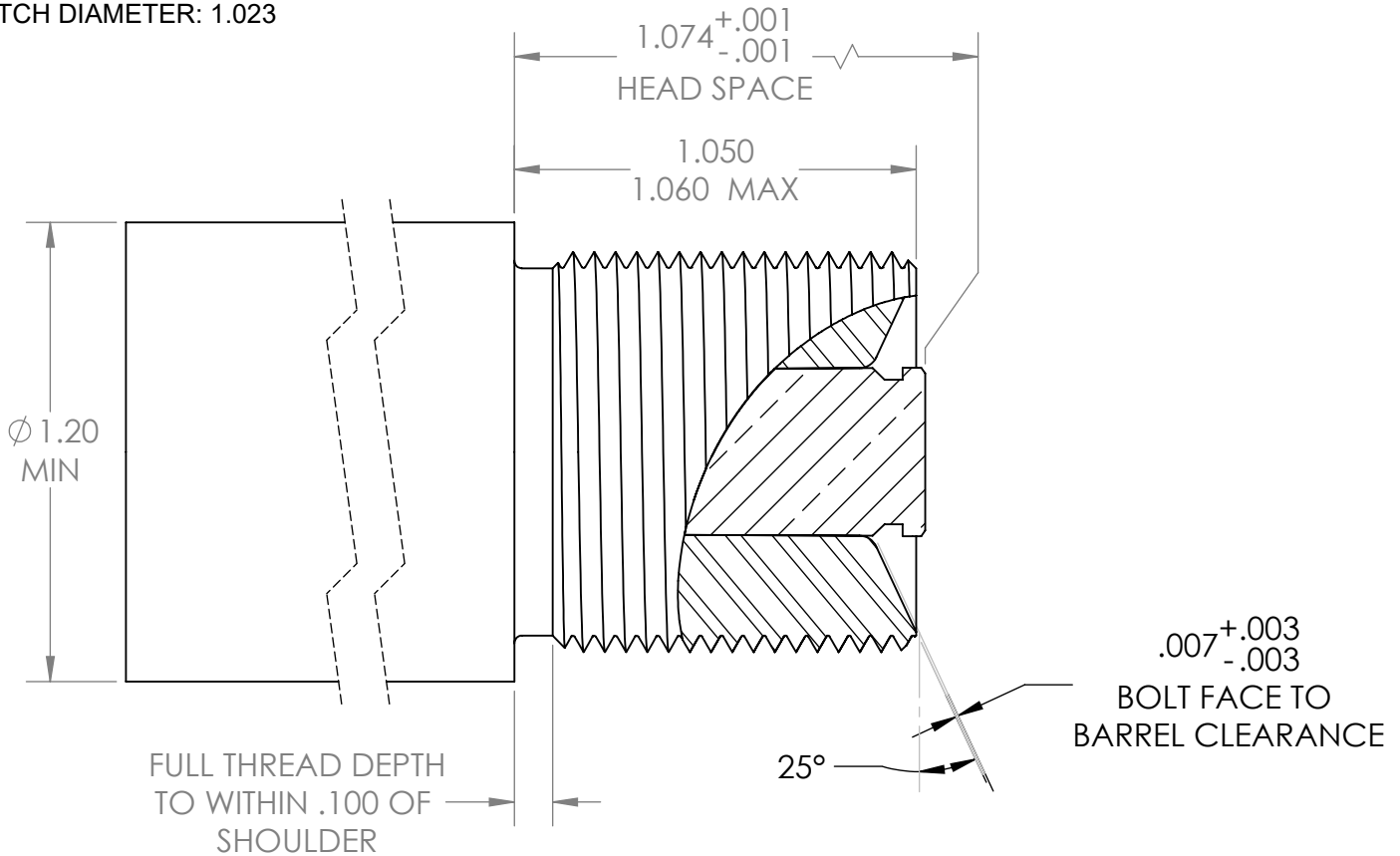

**WARNING:**

1. There have been some bastard actions due to customer request or rework. These utilize a 1-1/8 thread or oversize 1-1/16. It is your responsibility to verify the thread size in the action you are chambering for.
2. Length of thread extension & size of cone will vary depending on the size of the bolt face and must be individually fit.
3. BAT Machine Inc. builds custom actions that may or may not match this drawing, and does not accept any liability from the use or misuse of this information. ALL actions should be measured individually.
4. The end user is solely responsible for the safe use of the product.

<p><b>PROPRIETARY AND CONFIDENTIAL</b>          THE INFORMATION CONTAINED IN THIS DRAWING IS THE SOLE PROPERTY OF BAT MACHINE CO. INC. ANY REPRODUCTION IN PART OR AS A WHOLE WITHOUT THE WRITTEN PERMISSION OF BAT MACHINE CO. INC. IS PROHIBITED.</p>	<p><b>DIMENSIONS ARE IN INCHES TOLERANCES UNLESS OTHERWISE SPECIFIED:</b>          ANGULAR: ± 1 DEGREE          TWO PLACE DECIMAL ±.005          THREE PLACE DECIMAL ±.001</p>	NAME	DATE	<p><b>BAT Machine Co. Inc.</b></p> <p><b>1-1/16 X 18 BR</b></p>
		DRAWN	D. Thom	
	<p>MATERIAL</p> <p>FINISH</p> <p>DO NOT SCALE DRAWING</p>	CHECKED	B. Thom	12/5/2013
		ENG APPR.		
		MFG APPR.		
		Q.A.		
		COMMENTS:		
		SIZE	DWG. NO.	REV.
		<b>A</b>	tenon-1062	<b>B</b>
		SCALE:2:1	WEIGHT:	SHEET 1 OF 1